

ECO.50-T

Magnetic drilling machine

EUROBOOR

FOR PROFESSIONALS BY PROFESSIONALS

Technical data

	Metric	Imperial
Annular cutting	Ø 12 - 50 mm	Ø 1/2" - 2"
Twist drilling	Ø 1 - 23 mm	Ø 1/16" - 15/16"
Countersinking	Ø 10 - 55 mm	Ø 3/8" - 2 3/16"
Tapping	M3 - M20	Ø 1/8" - 13/16"
Length	320 mm	12 5/8"
Width	210 mm	8 1/4"
Height	385 - 540 mm	15 3/16" - 21 1/4"
Stroke	170 mm	6 11/16"
Weight*	13.5 kg	29.8 lbs
Magnet (l x w x h)	170 x 85 x 48 mm	6 11/16" x 3 3/8" x 1 7/8"
Magnetic force	1,850 kg	4,080 lbs
Motor power	1,250 W	11.4 A
Total power	1,375 W	12.5 A
Speed		(I) 100 - 280 rpm
(no load)		(II) 185 - 530 rpm
Speed		(I) 250 rpm
(load 1,250 W, 11.4 A)		(II) 460 rpm
Spindle (Weldon)	MT2 19.05 mm	MT2 3/4"
Voltage		110 - 120 V / 60 Hz
		220 - 240 V / 50 - 60 Hz

* Without power cord and handles

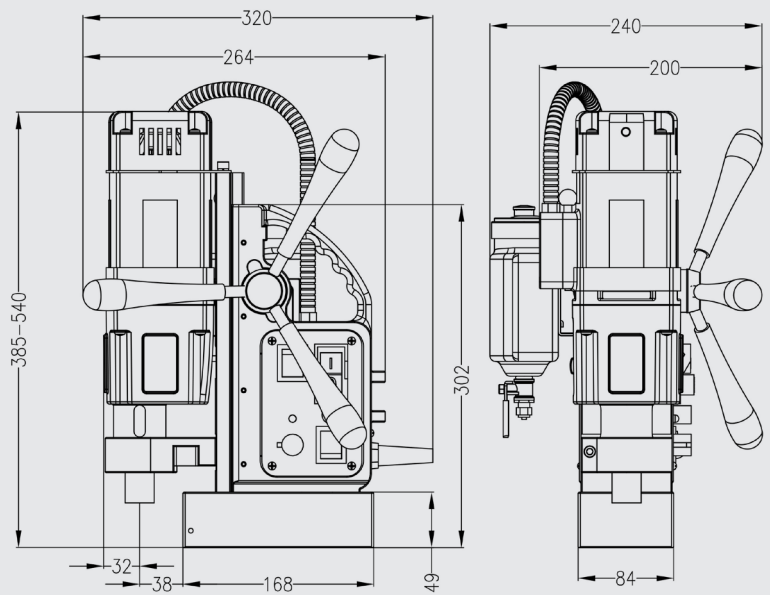

Features



Adjustable speed



R/L rotation



Overheat protection



Magnet LED-indicator (SensorTec)



Tapping



Euroboor makes every effort to meet quality and integrity requirements. That is why we as an organization are proud of the recognition of some leading organizations worldwide:



www.euroboor.com